

7929 Lincoln Ave. Riverside, CA 92504
 Phone: 951.689.ICON | Fax: 951.689.1016

PART #	DESCRIPTION
48612	21-UP BRONCO HOSS 2.0 PKG 2.5 REAR EXP COILOVER

COMPONENTS INCLUDED	
(1) 144935 21-UP BRONCO REAR C/O 2.5 EXP IR UNPKG	
HARDWARE INCLUDED	
(1) 148010 21-UP BRONCO SPRING ISOLATOR (1) 294060 EXP COIL MOUNT KIT	(1) 605360 1/2-20 FLANGED NYLOCK NUT GR8
TOOLS REQUIRED	
JACK JACK STANDS RATCHET, EXTENSIONS TORQUE WRENCH PHILLIPS SCREWDRIVER BODY PANEL CLIP REMOVAL TOOL SPRING COMPRESSOR	DRILL 1/2" DRILL BIT EXTERNAL RETAINING RING PLIERS 3/4" SOCKET / WRENCH 8MM SOCKET / WRENCH 15MM SOCKET / WRENCH 27MM SOCKET / WRENCH
TECH NOTES	
<p>1. YOUR ICON COILOVER ASSEMBLIES COME FACTORY CHARGED TO 250 PSI. RELEASING NITROGEN PRESSURE MAY LEAD TO SHOCK MALFUNCTION AND REDUCED RIDE QUALITY. FAILURE CAUSED BY LOW NITROGEN PRESSURE IS NOT COVERED UNDER ICON'S WARRANTY POLICY.</p> <p>2. SEE PAGE 6 FOR EXP SHOCK GROOVE SPECS.</p>	



WARNING!
<p>** READ ALL INSTRUCTIONS THOROUGHLY FROM START TO FINISH BEFORE BEGINNING INSTALLATION! IF THESE INSTRUCTIONS ARE NOT PROPERLY FOLLOWED SEVERE FRAME, SUSPENSION AND TIRE DAMAGE MAY RESULT TO THE VEHICLE!</p> <p>** ICON VEHICLE DYNAMICS RECOMMENDS THAT YOU EXERCISE EXTREME CAUTION WHEN WORKING UNDER A VEHICLE THAT IS SUPPORTED WITH JACK STANDS.</p> <p>** ICON VEHICLE DYNAMICS RECOMMENDS ALL INSTALLATION TO BE PERFORMED BY A PROFESSIONAL SHOP/SERVICE TECHNICIAN. PRODUCT FAILURE CAUSED BY IMPROPER INSTALLATION WILL NOT BE COVERED UNDER ICON'S WARRANTY POLICY.</p>

INSTALLATION

1. Lift vehicle and securely place heavy duty jack stands under the manufacturer recommended lifting locations for the front of the vehicle. Take care when lifting the vehicle, and allow 3-4" of ground clearance from the tire. Remove front tires. NEVER WORK UNDER AN UNSUPPORTED VEHICLE. Remove the wheels.

2. Remove Fender flare. Turn the 1/4 turn fasteners counter clockwise to release the flare. Then pull on flare and it will pop off the vehicle.



FIG.1

3. Remove inner fender liner. There are 10 plastic phillip head screw clips. 3 small phillip screws, 1 (driver side), 2 (passenger side) wing nuts to remove. [FIGURE 1 & 2]



FIG.2

4. Support the rear axle. Remove upper shock mount nuts (15mm). [FIGURE 3]

FIG.3



5. Remove lower shock bolt and nut using a 27mm and remove the factory coilover. [FIGURE 4]

FIG.4



6. Use a suitable spring compressor to compress the spring enough to remove the shaft nut inside the upper mount, using a 18mm. (The spring compressor pictured can be found on amazon.) mark the front of the upper mount, so it can be reinstalled the correct way. [FIGURE 5]

FIG.5



7. With the upper mount removed, use the drill and 1/2" drill bit to open up the center hole to fit onto the Icon EXP. [FIGURE 6]

FIG.6



8. Take the Icon EXP shock and install the supplied snap ring onto the body in the preferred groove. (Refer to the chart for your specific Bronco trim/Hoss package.) slide the supplied aluminum spring perch over the body as shown. Then slide the urethane coil seat onto the perch. [FIGURE 7, 8, 9, 10]

FIG.7



FIG.8



FIG.9



FIG.10



9. Install the supplied foam bumpstop with the tapered side facing the body, as shown. [FIGURE 11]

FIG.11



10. Install the factory spring onto the body, making sure the mark on the spring is facing the front of the shock. (The rear can be determined by the brass charge port.) Make sure the coil seat and end of the coil are correctly oriented. [FIGURE 12]

FIG.12

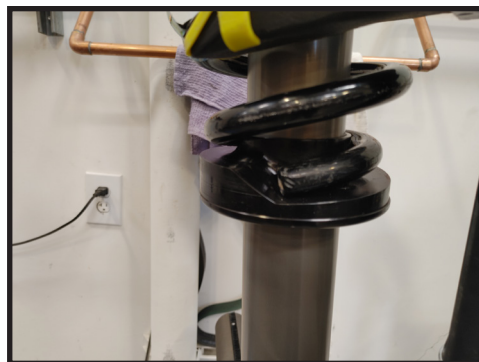

11. Compress the spring and install the factory upper mount, and tighten the supplied 1/2" flanged nylock nut with a 3/4" wrench/socket and an 8mm wrench to keep the shaft from spinning. Torque to 40-ft lbs. Make sure the mark on the upper mount is facing the front and the coil seat is matching up to the coil correctly. [FIGURE 13]

FIG.13

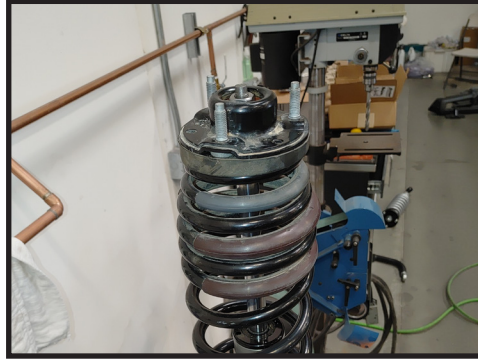

12. Remove the spring compressor and install the shock onto the truck, upper mount into the frame, and loosely install the 3 factory nuts. [FIGURE 14 & 15]

FIG.14



FIG.15



13. Install the lower spacers into the shock and line up the mount to slide the bolt into place. Torque bolt to factory spec with a 27mm. [FIGURE 16 & 17]

FIG.16



FIG.17



14. Torque the 3 upper mount nuts to factory spec with a 15mm. [FIGURE 18]

FIG.18



15. Reinstall the fender liner in reverse order as removal.

16. Repeat steps on passenger side.

**VERIFY ALL FASTENERS ARE PROPERLY TORQUED BEFORE DRIVING VEHICLE.
RETORQUE ALL NUTS, BOLTS AND LUGS AFTER 100 MILES AND PERIODICALLY THEREAFTER.**

2.5 VS SERIES SHOCK & COILOVER TECHNICAL INFORMATION

MAINTENANCE

ICON shock absorbers are a high quality rebuildable race style shock absorber designed for optimal performance. With a unit of this caliber on your vehicle, routine maintenance is required to keep them looking and operating in like new condition. Residual oil and assembly lube may be present at all seal paths from the factory out of the box and is considered normal. Pooling of oil however is not acceptable at any time and one should contact the ICON dealer where purchased.

BELOW ARE GUIDELINES BASED ON HOW YOU USE YOUR VEHICLE BUT YOUR MILEAGE MAY VARY:

STREET USE:

- Send in for factory servicing every 40,000 miles or if a leak develops, ride quality decreases, or they begin to make excessive noise.
- Remove any buildup of road salt, mud, or debris from shocks and coil springs anytime accrued
- Clean with mild soap and water with each oil change or anytime you notice build up.
- Wax the cylinders yearly with automotive wax to prevent corrosion.
- Check nitrogen pressure yearly. (252004 charge needle assembly available at any ICON distributor)
- Check bearings for excessive wear yearly.
- **DO NOT** apply any type of lube to the upper and lower bearings.

STREET/DIRT:

- Send in for factory servicing every 15,000 miles or if a leak develops, ride quality decreases, or they begin to make excessive noise.
- Clean with mild soap and water with each oil change, offroad trip, or anytime you notice build up.
- Wax the cylinders yearly with automotive wax to prevent corrosion.
- Check nitrogen pressure each dirt outing. (252004 charge needle assembly available at any ICON distributor)
- Check bearings for excessive wear yearly.
- **DO NOT** apply any type of lube to the upper and lower bearings.

DIRT USE:

- Send in for factory servicing every 1,000 miles.
- Check nitrogen pressure each outing. (252004 charge needle assembly available at any ICON distributor)
- Remove any buildup of mud or debris from shocks and coil springs after every outing.

SELF-SERVICE:

- Contact ICON for service kits & tools at (951) 689-4266.

PRODUCT REGISTRATION

Please visit: <http://www.iconvehicledynamics.com/tech-support/registration/> to register your product.

ICON VEHICLE DYNAMICS SHOCK ABSORBER WARRANTY

This shock absorber has a 1 year warranty against any manufacturer's defects. If a shock fails within the initial year of ownership, the shock must be shipped to ICON Vehicle Dynamics for inspection and service. If a shock is inspected and it has been determined the shock failed due to neglect, damage caused by improper installation or any other reason besides "normal wear and tear", the owner of said shock is responsible for all service costs. This includes labor, parts, and shipping.

ICON Vehicle Dynamics warrants to the original retail purchaser who owns the vehicle on which the product was originally installed. ICON Vehicle Dynamics does not warrant the product for finish, alterations, modifications and/or installation contrary to ICON Vehicle Dynamics instructions. ICON Vehicle Dynamics products are not designed, nor are they intended to be installed on vehicles used in race applications, for racing purposes or for similar activities. (A "race" is defined as any contest between two or more vehicles, or a contest of one or more vehicles against the clock, whether or not such contest is for a prize). This warranty does not include coverage for police or taxi vehicles, race vehicles, or vehicles used for government or commercial purposes. Also excluded from this warranty are sales outside of the United States of America and Canada.

ICON Vehicle Dynamics' obligation under this warranty is limited to the repair or replacement, at ICON Vehicle Dynamics' discretion, of the defective product. Any and all costs of removal, installation or re-installation, freight charges and incidental or consequential damages are expressly excluded from this warranty. Items that are subject to wear are not considered defective when worn and are not covered.

ICON Vehicle Dynamics components must be installed as a complete kit as shown in our current application guide. Any substitutions or exemptions of required components will immediately void the warranty. Some finish damage may happen to parts during shipping and is not covered under warranty.

This warranty is expressly in lieu of all other warranties expressed or implied. This warranty shall not apply to any product that has been improperly installed, modified or customized subject to accident, negligence, abuse or misuse.

To send a shock in for warranty please visit our website <http://www.iconvehicledynamics.com/tech-support/shock-service/>



ICON VEHICLE DYNAMICS®
PERFORMANCE SUSPENSION SYSTEMS AND SHOCK ABSORBERS

7929 Lincoln Ave. Riverside, CA 92504 Phone: 951.689.ICON Fax: 951.689.1016
www.iconvehicledynamics.com



FOLLOW US ON FACEBOOK!



ICON BRONCO FRONT EXP GROOVE SPECS

FENDER TO HUB MEASUREMENT

(FENDER FLARE REMOVED)

**HOSS 1.0 STOCK
RIDE HEIGHT: 22.75"**

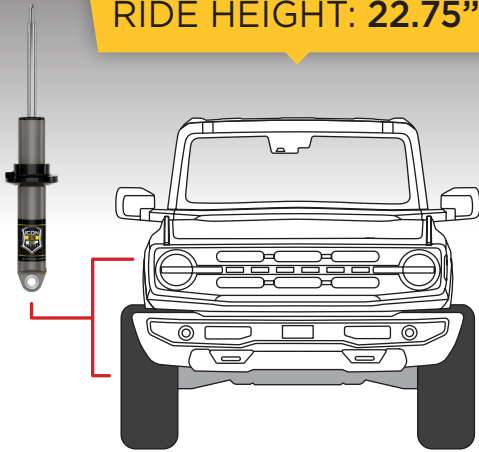

**HOSS 2.0 STOCK
RIDE HEIGHT: 23.5"**

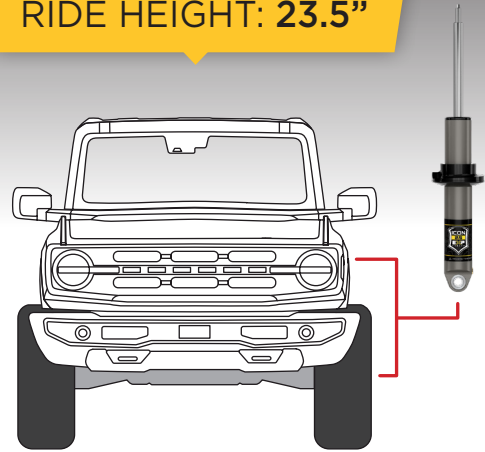

**GROOVE 1:
HOSS 1.0**



1.375" LIFT

**GROOVE 2:
HOSS 1.0**



2" LIFT

**GROOVE 3:
HOSS 2.0**

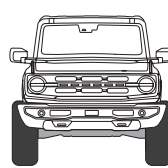

Stock Height

**GROOVE 4:
HOSS 2.0**

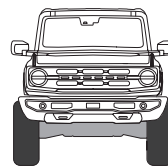

1.375" LIFT

**GROOVE 5:
HOSS 2.0**



2" LIFT

**GROOVE 1 & 2
ARE FOR HOSS 1.0
SPRINGS ONLY**

IF YOU USE ANY OTHER
GROOVE, THE FACTORY
SPRING CAN BE DAMAGED.



**GROOVE 3-5
ARE FOR HOSS 2.0
SPRINGS ONLY**

IF YOU USE ANY OTHER
GROOVE, THE FACTORY
SPRING CAN BE DAMAGED.